



FORD  
**TRANSIT**



# **UPFIT GUIDE**





# HELPING MOBILE TECHNICIANS WORK MORE EFFECTIVELY BY PROVIDING ORGANIZED STORAGE SOLUTIONS

## AT RANGER DESIGN, WE BELIEVE MORE IS POSSIBLE.

We believe work vehicles and the technicians that drive them can become more organized, more efficient, more productive and more profitable. At Ranger Design we're committed to bringing you the products and services that make that possible.

More means helping you choose the right work van for your application, as well as giving you engineering support and expert advice to help design the most efficient work space in your new vehicle.

More also means getting that new van outfitted and on the road faster, so you can start using it for the reason you bought it.

We're committed to bringing you more, because we believe more is possible.



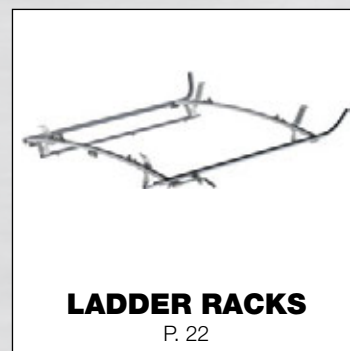
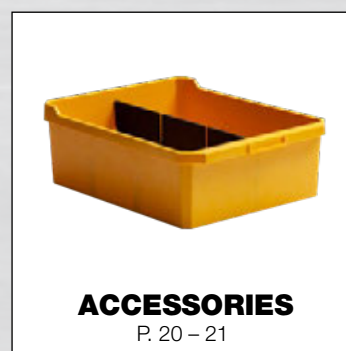

## Over 350 Distributors Across the Continent

**Buy** Ranger Design Quickship service is available through your local distributor. [rangerdesign.com/find-dealer](http://rangerdesign.com/find-dealer)

**Lead Time** Quickship orders placed with Ranger Design before 1PM EST, will ship from our factory in the next business day.



All products shown in this upfit guide are available on Quickship



# HOW TO USE THE LAYOUT GUIDE

## INSIDE ROOF HEIGHT

To determine the maximum shelf height that can be used in the van.

## PARTITION DEPTH

This indicates the space taken up by our partition for this vehicle. Please note that this measurement is determined by the partition that encroaches the most. Some partitions may take up less space. Take note that this measurement may not necessarily be on the floor.

## DOOR OPENING

To determine where shelving will land in relation to the door opening. Use this measurement to determine the space available for drawer units.

## DIMENSIONS IN RED

These dimensions indicate unique measurements for each wheelbase. Use red dimensions to determine the exact wheelbase of your van.

## FLOOR SPACE

This area is usable floor space but due to curvature of the van there may not be the same available area at the roof. Please measure actual van for specific measurement at roof.

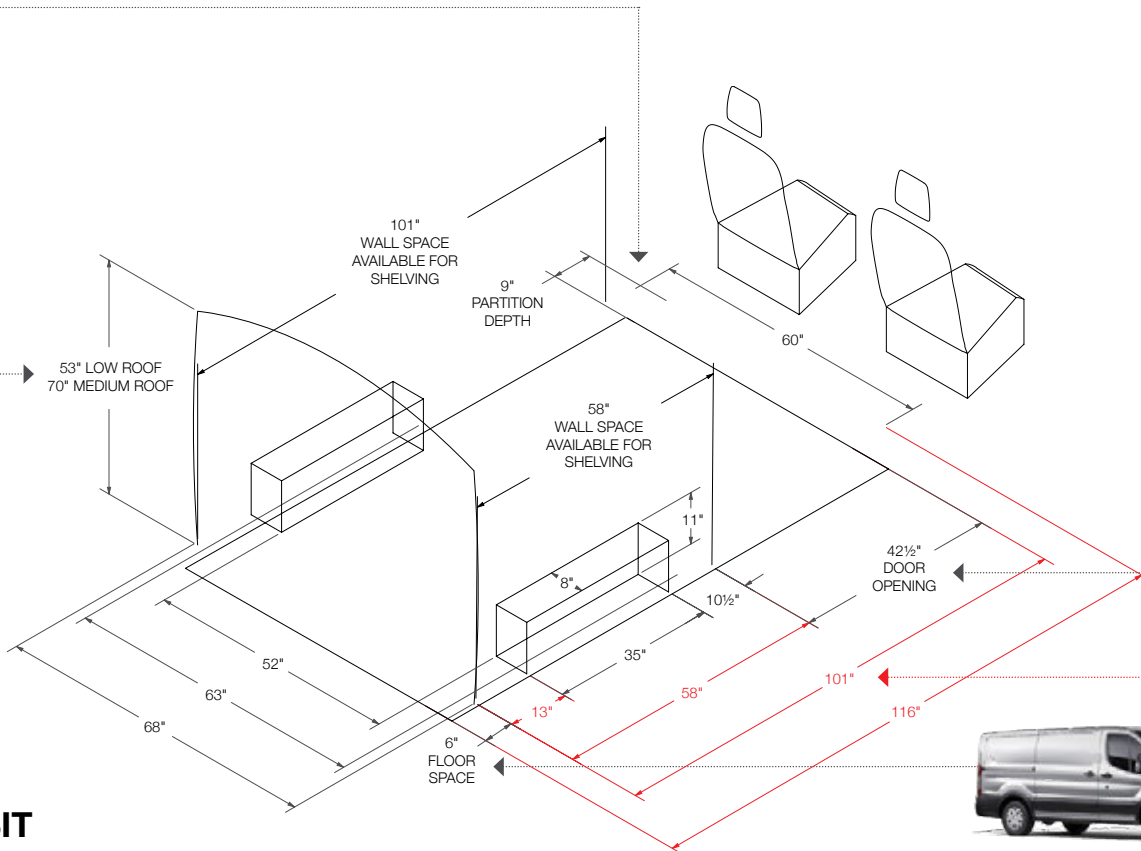

**FORD TRANSIT**  
Regular 130" Wheelbase



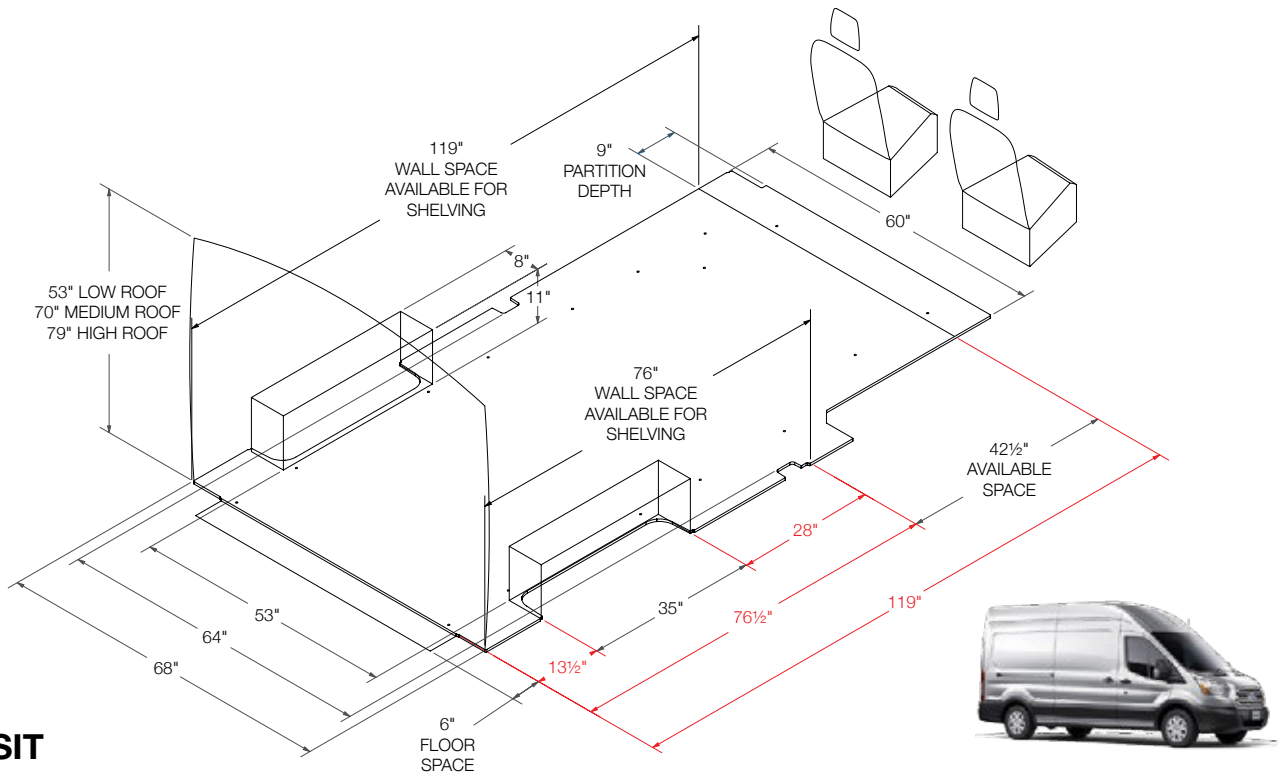

**FORD  
TRANSIT**  
Long 148" Wheelbase

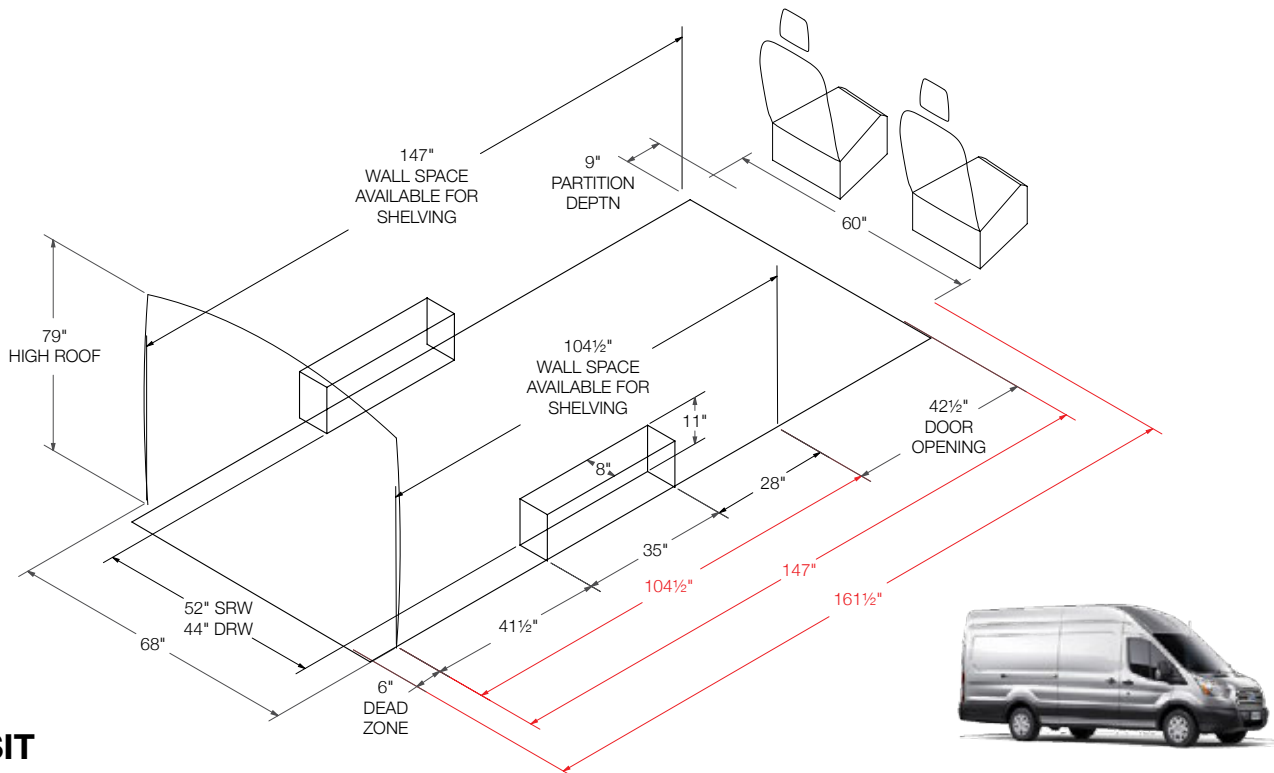

**FORD  
TRANSIT**  
Long 148" Wheelbase Extended

# CONTRACTOR

CONTRACTOR

## FTL-10

130" OR 148" WHEELBASE

> Low Roof



Qty	Part #	Description
1	6070	6" Hook, 3" opening, painted
1	C20-FTL	Straight steel partition with perforated window, no access
1	N4-RS48-3	Steel shelving unit for low roof van, 14" D x 48" W x 44.5" H
1	N4-RS84-3	Steel shelving unit for low roof van, 14" D x 84" W x 44.5" H

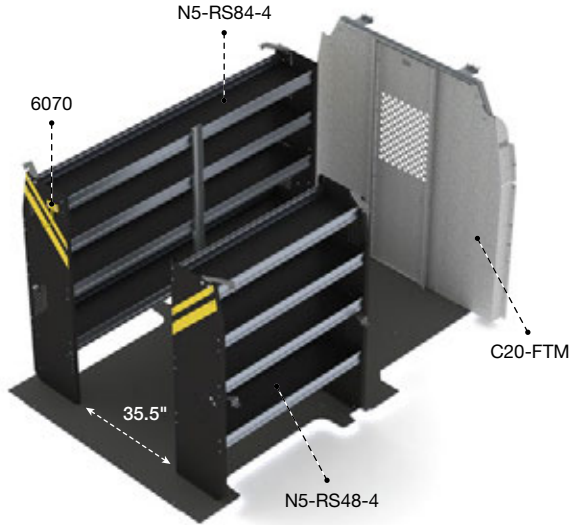
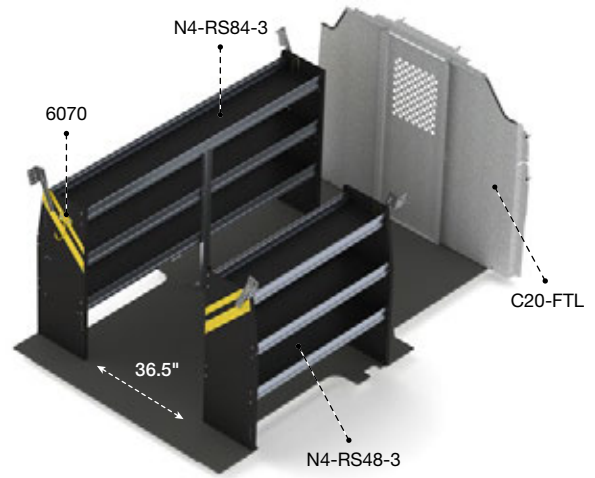

## FTR-10

130" WHEELBASE

> Medium Roof



Qty	Part #	Description
1	6070	6" Hook, 3" opening, painted
1	C20-FTM	Straight steel partition with perforated window, no access
1	N5-RS48-4	Steel shelving unit for high roof van, 14" D x 48" W x 62" H
1	N5-RS84-4	Steel shelving unit for high roof van, 14" D x 84" W x 62" H

## FTM-10

148" WHEELBASE

> Medium Roof

Qty	Part #	Description
1	6070	6" Hook, 3" opening, painted
1	C20-FTM	Straight steel partition with perforated window, no access
1	N5-RS60-4	Steel shelving unit for high roof van, 14" D x 60" W x 62" H
1	N5-RS96-4	Steel shelving unit for high roof van, 14" D x 96" W x 62" H

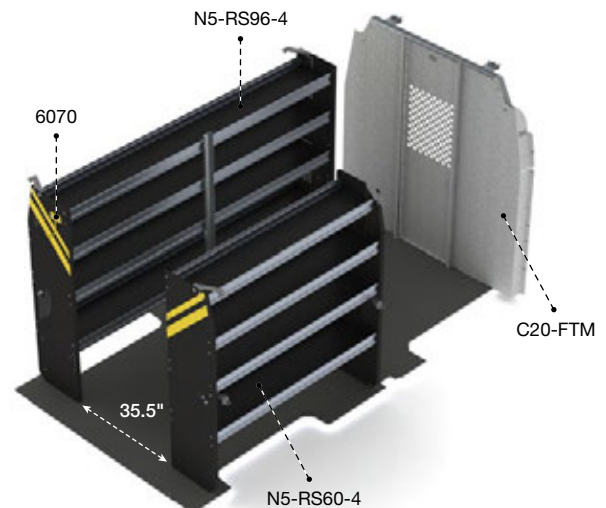



C20-FTH

## FTH-10

FTH-10 Package\* is identical to FTM-10 Package with the exception of the partition which changes to C20-FTH

\*For High Roof 148" & 148" Extended

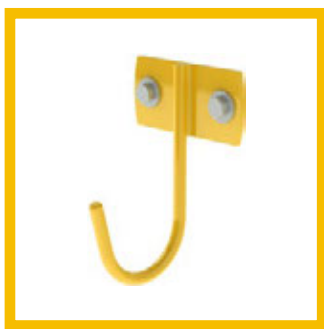

## 6070

6" Hook,  
3" opening,  
painted



# SERVICE

## FTL-16

130" OR 148" WHEELBASE

> Low Roof



Qty	Part #	Description
1	6070	6" Hook, 3" opening, painted
1	6072	8" Swivel hook, 4" opening, painted
4	62-U1114	14" Deep plastic bin
1	62-UDR12	Set of 5 dividers for a 12" shelf
1	62-UDR14	Set of 5 dividers for a 14" shelf
1	C20-FTL	Straight steel partition with perforated window, no access
1	N4-RS48-3	Steel shelving unit for low roof van, 14" D x 48" W x 44.5" H
1	N4-RS84-3	Steel shelving unit for low roof van, 14" D x 84" W x 44.5" H
2	X50-B	Compact 2-drawer unit

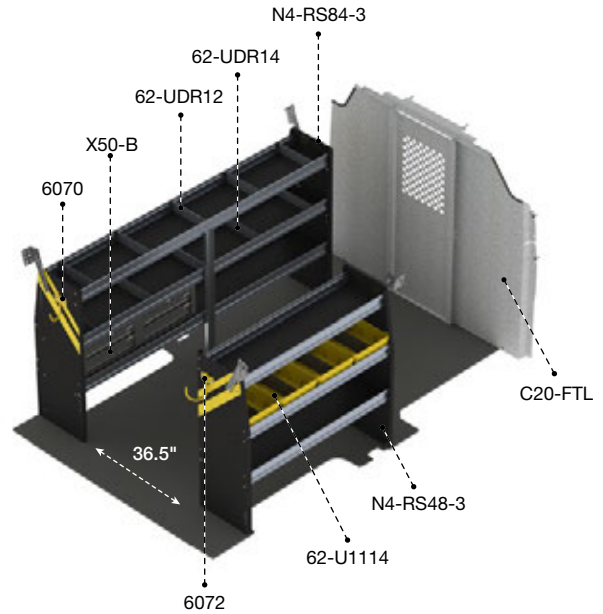

SERVICE

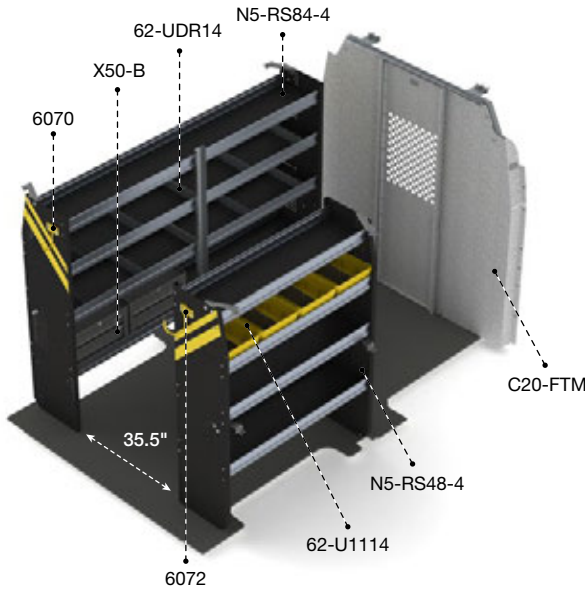

## FTR-16

130" WHEELBASE

> Medium Roof



Qty	Part #	Description
1	6070	6" Hook, 3" opening, painted
1	6072	8" Swivel hook, 4" opening, painted
4	62-U1114	14" Deep plastic bin
2	62-UDR14	Set of 5 dividers for a 14" shelf
1	C20-FTM	Straight steel partition with perforated window, no access
1	N5-RS48-4	Steel shelving unit for low roof van, 14" D x 48" W x 62" H
1	N5-RS84-4	Steel shelving unit for low roof van, 14" D x 84" W x 62" H
2	X50-B	Compact 2-drawer unit

## FTM-16

148" WHEELBASE

> Medium Roof

Qty	Part #	Description
1	6070	6" Hook, 3" opening, painted
1	6072	8" Swivel hook, 4" opening, painted
5	62-U1114	14" Deep plastic bin
2	62-UDR14	Set of 5 dividers for a 14" shelf
1	C20-FTM	Straight steel partition with perforated window, no access
1	N5-RS60-4	Steel shelving unit for high roof van, 14" D x 60" W x 62" H
1	N5-RS96-4	Steel shelving unit for high roof van, 14" D x 96" W x 62" H
2	X50-B	Compact 2-drawer unit

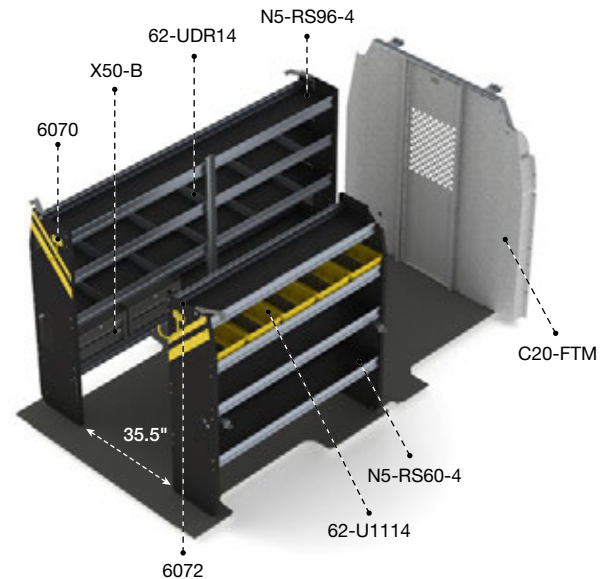





C20-FTH

## FTH-16

FTH-16 Package\* is identical to FTM-16 Package with the exception of the partition which changes to C20-FTH

\*For High Roof 148" & 148" Extended



### 6072

8" Swivel hook,  
4" opening, painted



### X50-B

2 Drawer cabinet



### 62-U1114

14" Deep plastic bin  
with a center divider

FOR MORE ACCESSORIES, SEE PAGE 20.

# ELECTRICAL

## FTL-11

### 130" OR 148" WHEELBASE

#### > Low Roof



Qty	Part #	Description
1	6063	Paper holder, extra deep, 5 slots
1	6070	6" Hook, 3" opening, painted
1	6072	8" Swivel hook, 4" opening, painted
7	62-U1112	12" Deep plastic bin
2	62-UDR14	Set of 5 dividers for a 14" shelf
1	7124	Reel holder with two 5/8" diameter rods
1	77-U1036	Adjustable shelving door unit - 33" W - for 36" and 72" shelves
1	77-U1048	Adjustable shelving door unit - 45" W - for 48" and 96" shelves
1	C20-FTL	Straight steel partition with perforated window, no access
1	N4-RS48-3	Steel shelving unit for low roof van, 14"D x 48" W x 44.5"H
1	N4-RS84-3	Steel shelving unit for low roof van, 14"D x 84" W x 44.5"H
1	X50-B	Compact 2-drawer unit
1	X50-C	Compact 3-drawer unit

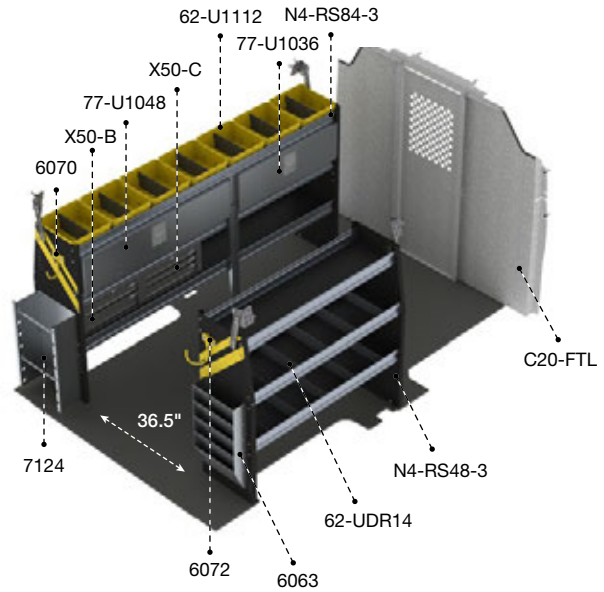

ELECTRICAL

## FTR-11

### 130" WHEELBASE

#### > Medium Roof



Qty	Part #	Description
1	6063	Paper holder, extra deep, 5 slots
1	6070	6" Hook, 3" opening, painted
1	6072	8" Swivel hook, 4" opening, painted
7	62-U1114	14" Deep plastic bin
2	62-UDR14	Set of 5 dividers for a 14" shelf
1	7124	Reel holder with two 5/8" diameter rods
1	77-U1036	Adjustable shelving door unit - 33" W - for 36" and 72" shelves
1	77-U1048	Adjustable shelving door unit - 45" W - for 48" and 96" shelves
1	C20-FTM	Straight steel partition with perforated window, no access
1	N5-RS48-4	Steel shelving unit for high roof van, 14" D x 48" W x 62" H
1	N5-RS84-4	Steel shelving unit for high roof van, 14" D x 84" W x 62" H
1	X50-B	Compact 2-drawer unit
1	X50-C	Compact 3-drawer unit

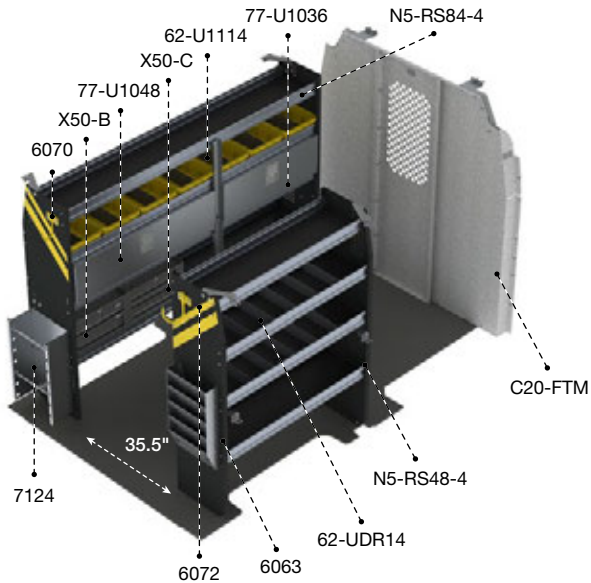

## FTM-11

### 148" WHEELBASE

#### > Medium Roof

Qty	Part #	Description
1	6063	Paper holder, extra deep, 5 slots
1	6070	6" Hook, 3" opening, painted
1	6072	8" Swivel hook, 4" opening, painted
8	62-U1114	14" Deep plastic bin
2	62-UDR14	Set of 5 dividers for a 14" shelf
1	7124	Reel holder with two 5/8" diameter rods
2	77-U1048	Adjustable shelving door unit - 45" W - for 48" and 96" shelves
1	C20-FTM	Straight steel partition with perforated window, no access
1	N5-RS60-4	Steel shelving unit for high roof van, 14" D x 60" W x 62" H
1	N5-RS96-4	Steel shelving unit for high roof van, 14" D x 96" W x 62" H
1	X50-B	Compact 2-drawer unit
1	X50-C	Compact 3-drawer unit

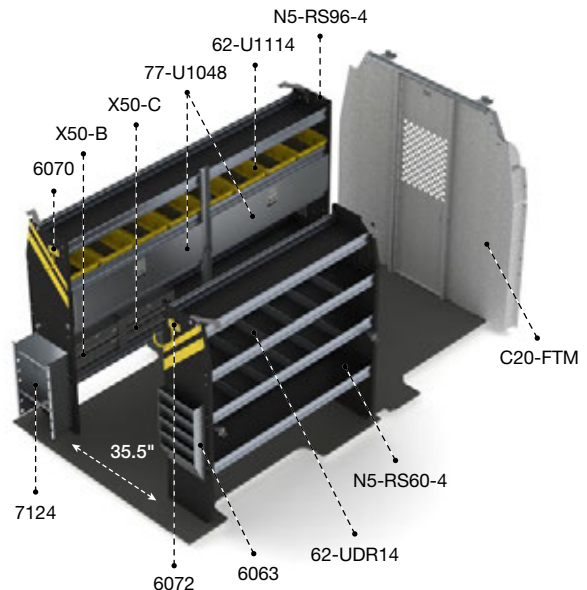



**C20-FTH**

## FTH-11

**FTH-11 Package\*** is identical to FTM-11 Package with the exception of the partition which changes to C20-FTH

\*For High Roof 148" & 148" Extended



### 62-U1110, 62-U1112, 62-U1114

Plastic bins with a center divider  
Available in 10", 12" or 14" depths



### 62-U1212

2 Cross dividers for bin  
Fits all size bins



### 77-U1042

Adjustable shelving door  
unit 39" wide for a 84" shelf

**FOR MORE ACCESSORIES, SEE PAGE 20.**



## FTL-12

130" OR 148" WHEELBASE

> Low Roof



Qty	Part #	Description
1	6008	3 Tier refrigerant rack for large bottles
1	6063	Paper holder, extra deep, 5 slots
1	6070	6" Hook, 3" opening, painted
1	6072	8" Swivel hook, 4" opening, painted
1	6088	Large aluminum bottle holder, with two black nylon straps
7	62-U1114	14" Deep plastic bin
2	62-UDR14	Set of 5 dividers for a 14" shelf
1	77-U1048	Adjustable shelving door unit - 45" W - for 48" & 96" shelves
1	C20-FTL	Straight steel partition with perforated window, no access
1	N4-RS48-3	Steel shelving unit for low roof van, 14" D x 48" W x 44.5" H
1	N4-RS84-3	Steel shelving unit for low roof van, 14" D x 84" W x 44.5" H
2	X50-B	Compact 2-drawer unit

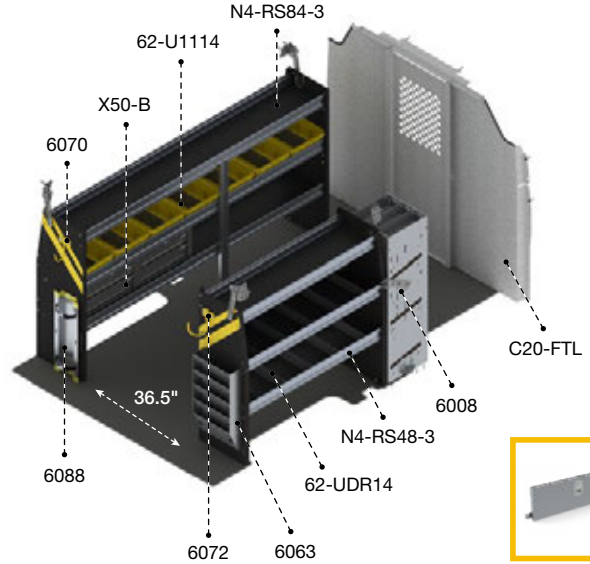

77-U1048

## FTR-12

130" WHEELBASE

> Medium Roof



Qty	Part #	Description
1	6008	3 Tier refrigerant rack for large bottles
1	6063	Paper holder, extra deep, 5 slots
1	6070	6" Hook, 3" opening, painted
1	6072	8" Swivel hook, 4" opening, painted
1	6088	Large aluminum bottle holder, with two black nylon straps
7	62-U1114	14" Deep plastic bin
2	62-UDR14	Set of 5 dividers for a 14" shelf
1	77-U1048	Adjustable shelving door unit - 45" W - for 48" & 96" shelves
1	C20-FTM	Straight steel partition with perforated window, no access
1	N5-RS48-4	Steel shelving unit for high roof van, 14" D x 48" W x 62" H
1	N5-RS84-4	Steel shelving unit for high roof van, 14" D x 84" W x 62" H
2	X50-B	Compact 2-drawer unit

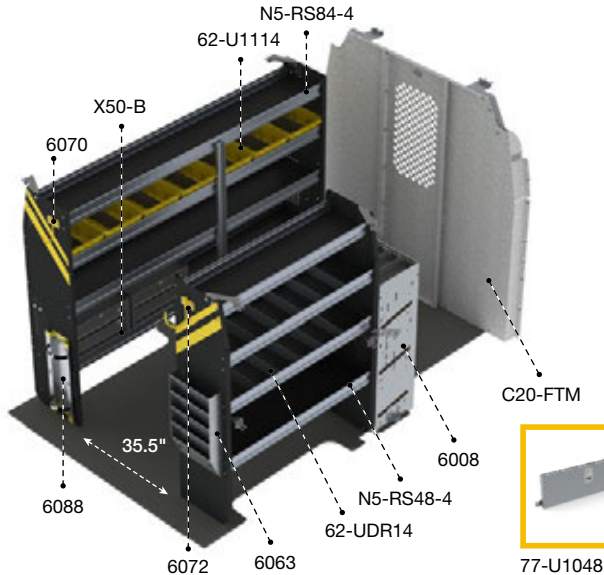

77-U1048

## FTM-12

148" WHEELBASE

> Medium Roof

Qty	Part #	Description
1	6008	3 Tier refrigerant rack for large bottles
1	6063	Paper holder, extra deep, 5 slots
1	6070	6" Hook, 3" opening, painted
1	6072	8" Swivel hook, 4" opening, painted
1	6088	Large aluminum bottle holder, with two black nylon straps
8	62-U1114	14" Deep plastic bin
2	62-UDR14	Set of 5 dividers for a 14" shelf
1	77-U1060	Adjustable shelving door unit - 57" W - for 60" shelves
1	C20-FTM	Straight steel partition with perforated window, no access
1	N5-RS60-4	Steel shelving unit for high roof van, 14" D x 60" W x 62" H
1	N5-RS96-4	Steel shelving unit for high roof van, 14" D x 96" W x 62" H
2	X50-B	Compact 2-drawer unit

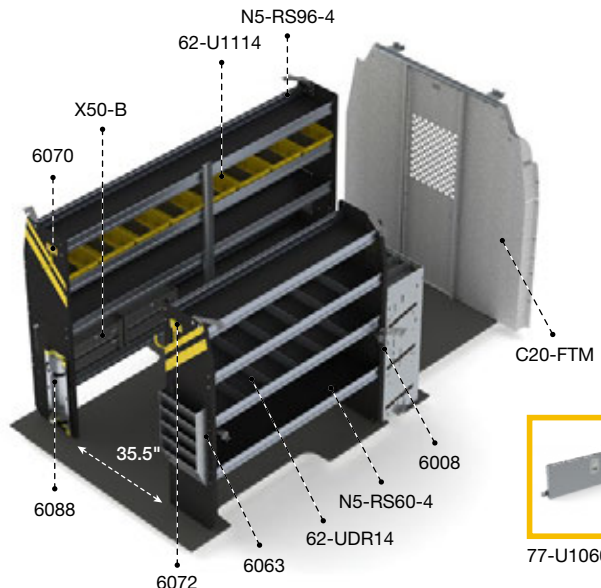

77-U1060







C20-FTH

### FTH-12

FTH-12 Package\* is identical to FTM-12 Package with the exception of the partition which changes to C20-FTH

\*For High Roof 148" & 148" Extended



### 62-UDR14

Set of 5 dividers for a 14" shelf



### 6088

Large aluminum bottle holder, with two black nylon straps



### 6008

3 Tier refrigerant rack for large bottles

FOR MORE ACCESSORIES, SEE PAGE 20.

## FTL-19

130" OR 148" WHEELBASE

> Low Roof



Qty	Part #	Description
1	8548-2	Fold-away shelving unit, 2 levels, 18"D x 55" W x 53.5"H
1	8572-2	Fold-away shelving unit, 2 levels, 18"D x 79" W x 53.5"H
1	C24-FTL	Straight walk through steel partition

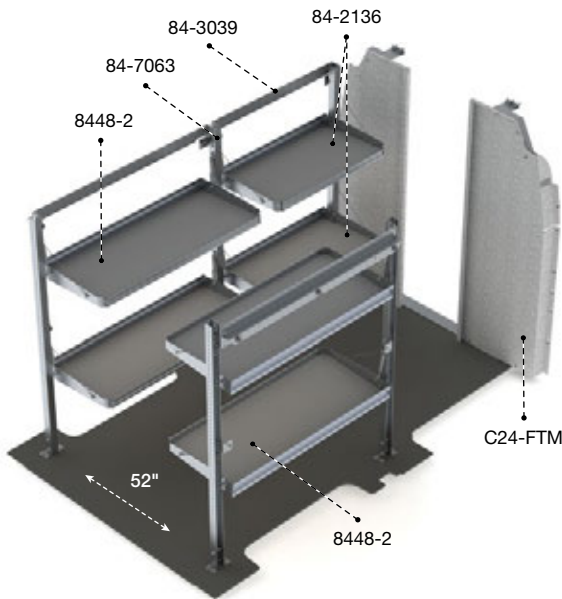
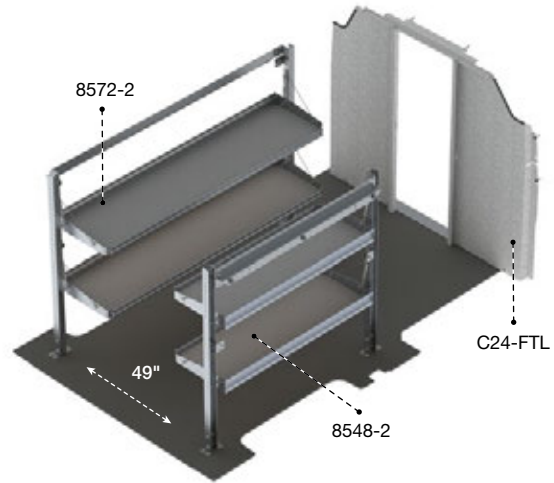

## FTR-19

130" WHEELBASE

> Medium Roof



Qty	Part #	Description
2	84-2136	Fold-away shelf tray with gas shocks and hardware 21" D x 36" W
1	84-3039	Mounting bar assembly, 36", Fold-Away
2	8448-2	Fold-away shelving unit, 2 levels, 21"D x 55" W x 63.5"H
1	84-7063	Post assembly for fold-away shelving, 63.5" H
1	C24-FTM	Straight walk through steel partition

## FTM-19

148" WHEELBASE

> Medium Roof

Qty	Part #	Description
2	84-2136	Fold-away shelf tray with gas shocks and hardware 21" D x 36" W
1	84-3039	Mounting bar assembly, 36", Fold-Away
1	8458-2	Fold-away shelving unit, 2 levels, 21"D x 65" W x 63.5"H
1	84-7063	Post assembly for fold-away shelving, 63.5" H
1	8472-2	Fold-away shelving unit, 2 levels, 21"D x 79" W x 63.5"H
1	C24-FTM	Straight walk through steel partition

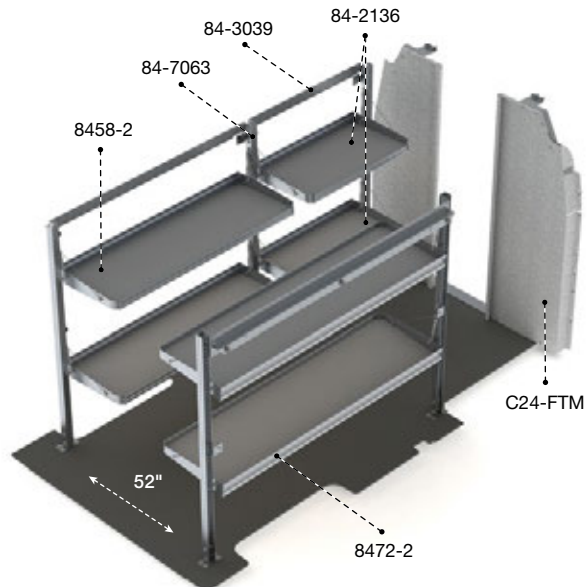



C24-FTH

### FTH-19

FTH-19 Package\* is identical to FTM-19 Package with the exception of the partition which changes to C24-FTH

\*For High Roof 148" & 148" Extended

DELIVERY

## YOUR PERSONAL FLEX SPACE

**Our fold-away shelves are designed to give you the ultimate in cargo flexibility**

- > Flexible
- > Easy to use
- > Tough



## THE BENEFITS OF **ALUMINUM**

### **Weight saving equipment reduces total cost of ownership**



Optimize fuel economy by decreasing overall van mass



Reduce vehicle maintenance and repairs caused by weight overload



Increase payload without sacrificing quality – it's a benefit offered only by aluminum

**Did you know that for every 100 lbs reduction,  
you increase fuel economy by 1%?**

[www.fueleconomy.gov](http://www.fueleconomy.gov)

**Ranger Design is the leader for  
aluminum upfits in North America**





## FTL-27

130" OR 148" WHEELBASE

> Low Roof



Qty	Part #	Description
1	3320-FTL	Max View contoured safety partition
1	5010	Partslider 48" D
1	5020	Tool drawer 48" D x 14" W x 16" H
1	5048	Top edge
1	5069-2	2 Drawer cabinet
2	5070	Partskeeper carry case with holder
1	6070	6" Hook, 3" opening, painted
1	6072	8" Swivel hook, 4" opening, painted
4	62-U1112	12" Deep plastic bin
8	62-U1114	14" Deep plastic bin
1	62-UDR12	Set of 5 dividers for a 12" shelf
1	62-UDR14	Set of 5 dividers for a 14" shelf
1	77-U1048	Adjustable shelving door unit - 45" W - for 48" & 96" shelves
1	N4-RA48-3	Aluminum shelving unit for low roof van, 14"D x 48" W x 44.5" H
1	N4-RA84-3	Aluminum shelving unit for low roof van, 14"D x 84" W x 44.5" H

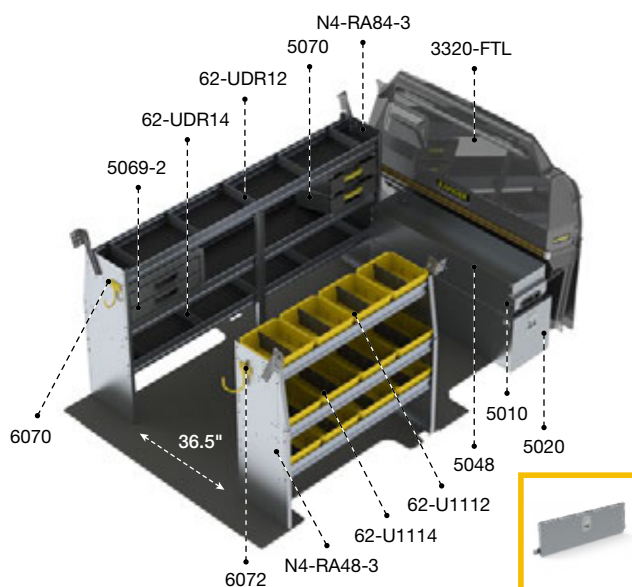

77-U1048

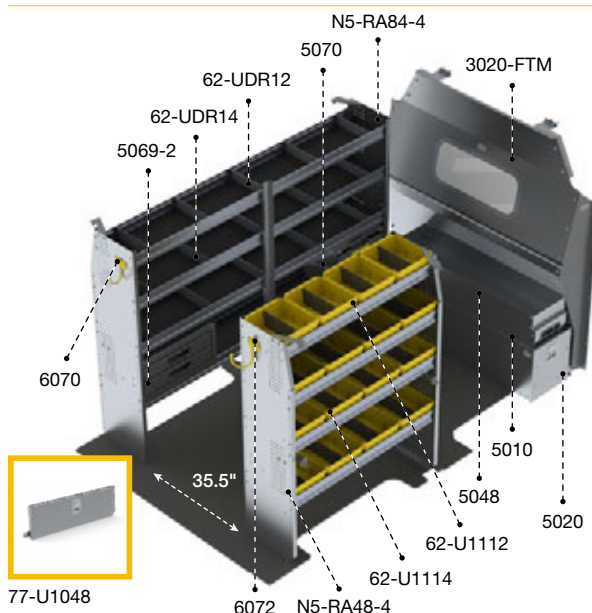

77-U1048

## FTR-27

130" WHEELBASE

> Medium Roof



Qty	Part #	Description
1	3020-FTM	Countoured safety partition with tempered glass window
1	5010	Partslider 48" D
1	5020	Tool drawer 48" D x 14" W x 16" H
1	5048	Top edge
1	5069-2	2 Drawer cabinet
2	5070	Partskeeper carry case with holder
1	6070	6" Hook, 3" opening, painted
1	6072	8" Swivel hook, 4" opening, painted
4	62-U1112	12" Deep plastic bin
12	62-U1114	14" Deep plastic bin
1	62-UDR12	Set of 5 dividers for a 12" shelf
2	62-UDR14	Set of 5 dividers for a 14" shelf
1	77-U1048	Adjustable shelving door unit - 45" W - for 48" & 96" shelves
1	N5-RA48-4	Aluminum shelving unit for high roof van, 14"D x 48" W x 62"H
1	N5-RA84-4	Aluminum shelving unit for high roof van, 14"D x 84" W x 62"H

## FTM-27

148" WHEELBASE

> Medium Roof



Qty	Part #	Description
1	3020-FTM	Countoured safety partition with tempered glass window
1	5010	Partslider 48" D
1	5020	Tool drawer 48" D x 14" W x 16" H
1	5048	Top edge
1	5069-2	2 Drawer cabinet
2	5070	Partskeeper cabinets
1	6070	6" Hook, 3" opening, painted
1	6072	8" Swivel hook, 4" opening, painted
5	62-U1112	12" Deep plastic bin
15	62-U1114	14" Deep plastic bin
1	62-UDR12	Set of 5 dividers for a 12" shelf
2	62-UDR14	Set of 5 dividers for a 14" shelf
1	77-U1060	Adjustable shelving door unit - 57" W - for 60" shelves
1	N5-RA60-4	Aluminum shelving unit for high roof van, 14"D x 60" W x 62" H
1	N5-RA96-4	Aluminum shelving unit for high roof van, 14"D x 96" W x 62" H

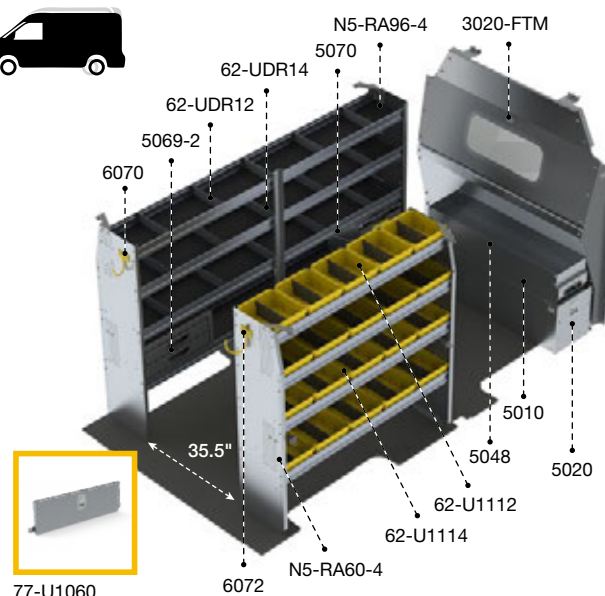

77-U1060



3020-FTH

## FTH-27

**FTH-27 Package\*** is identical to FTM-27 Package with the exception of the partition which changes to 3020-FTH

\*For High Roof 148" & 148" Extended

# AN ERGONOMIC SOLUTION TO STORAGE

## Ranger Design tool drawers offer:

- Accessibility
- Organization
- Security
- Lockable

**5020** Tool drawer mounted with a **5010** Partslider drawer and **5048** Top edge.



# IT'S MORE THAN A FLOOR!

With incorporated mounting tracks for easy install for most Ranger Design products.

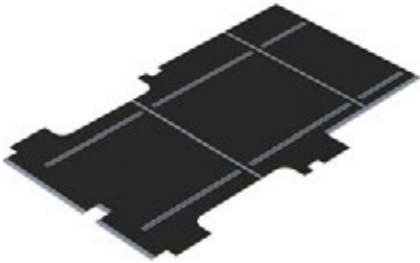

**6540-FTS**

Ford Transit 130" Floor

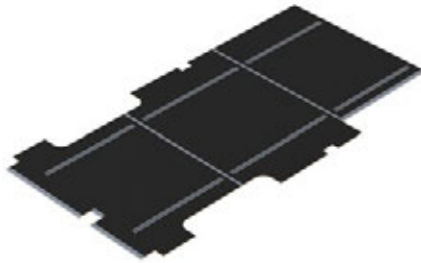

**6540-FTL**

Ford Transit 148" Floor

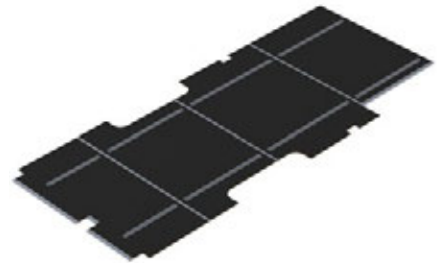

**6540-FTX**

Ford Transit 148" Ext

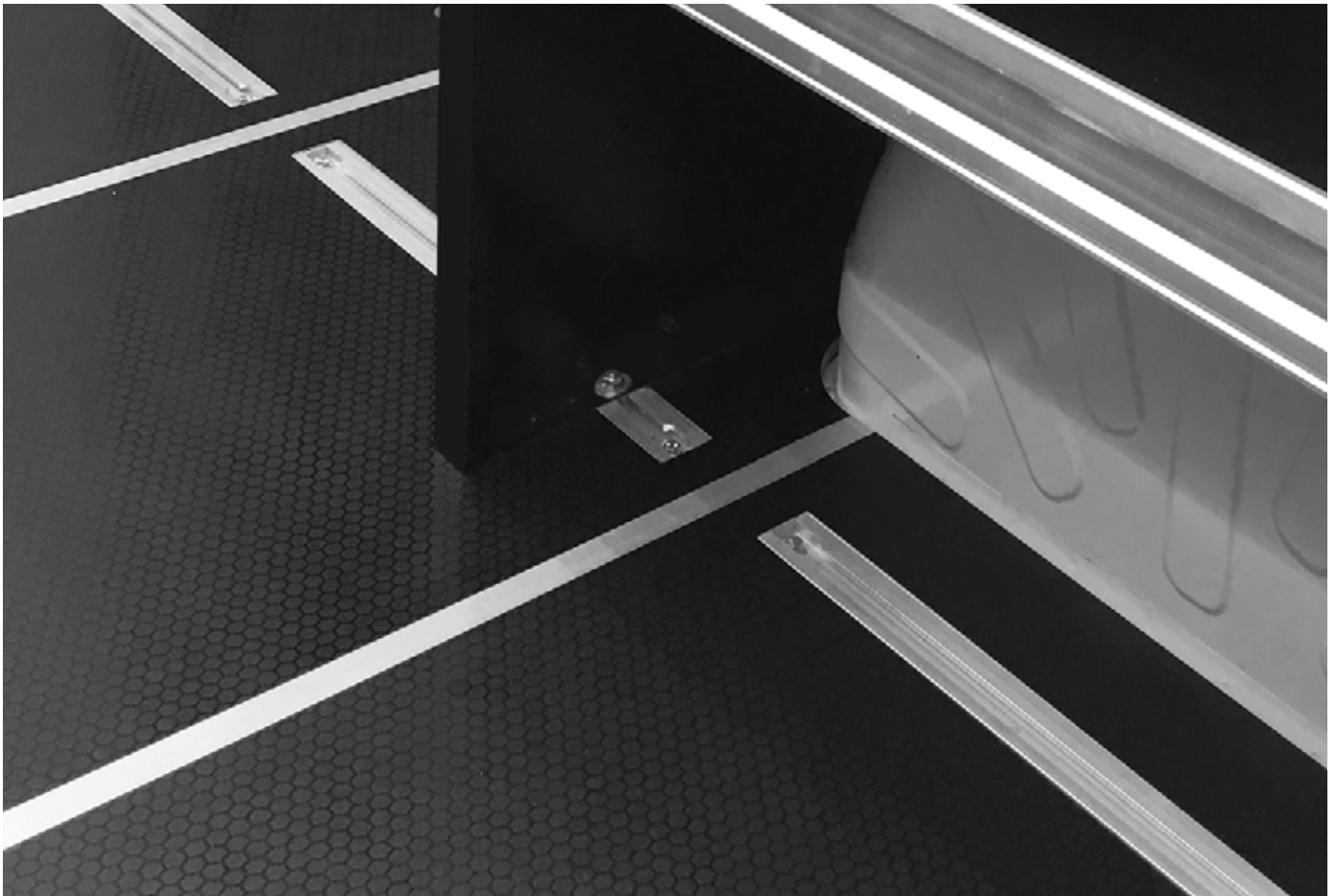

**Impact and puncture resistant floors**  
 Preserve the cargo van interior

# ACCESSORIES



**5070**

Partskeeper carry case with holder, universal



**6010**

Two level adjustable bottle holder



**6041**

Locking cabinet

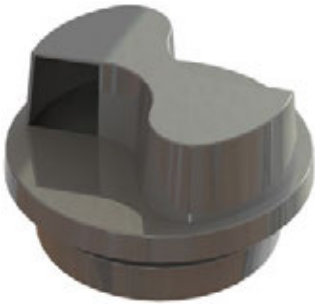

**6050**

Flettner vent, rotary design



**NEW!**

- > Safe and easy access to your vehicle
- > Rugged grip in any weather

**6550-FT**  
Max Step

Available Fall 2018



**6057**

Can holder



**6063**

Paper holder, extra deep, 5 slots



**6068**

Hard hat holder, painted wire





## 6073

Large aluminum movable hook, 6.5" opening

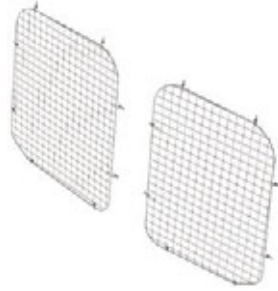

## 6121

Set of 2 rear window grills for medium and high roof

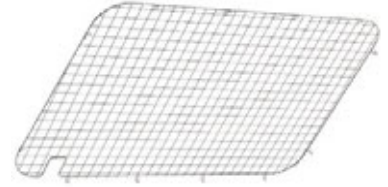

## 6123

Window grill, passenger side sliding door



## 62-U1110, 62-U1112, 62-U1114

10", 12" or 14" Deep plastic bin  
All bins come with a center divider



## 62-U1212

2 Cross dividers for plastic bins  
Fits all size bins



## 62-UDR10, 62-UDR12, 62-UDR14

Set of 5 dividers for a 10", 12" or 14" shelf



## 7124

Reel holder with two 5/8" diameter rods



## 6255

Seat covers

### ENHANCE YOUR VEHICLE WITH CUSTOM SEAT COVERS



- > Machine wash and dryer safe
- > No interference with factory seat functions (heating, cooling or air bag)
- > Tight custom fit for each vehicle, guaranteed to stay in place
- > Puncture resistant to prevent seat damage

# LADDER RACKS



Ford Transit  
Cargo rack



**Aluminum**

			
<b>1505-FTR</b>	130"	Low, Medium	
<b>1505-FTL</b>	148", 148" Ext	Low, Medium, High	



Ford Transit  
Cargo rack



**Aluminum**

			
<b>1505-FTR3</b>	130"	Low, Medium	
<b>1505-FTL3</b>	148", 148" Ext	Low, Medium, High	



Ford Transit  
Double clamp ladder rack



**Aluminum**

			
<b>1530-FTR</b>	130"	Low, Medium	32 ft
<b>1530-FTL</b>	148", 148" Ext	Low, Medium, High	32 ft



Ford Transit  
Max Rack, Single side ladder rack

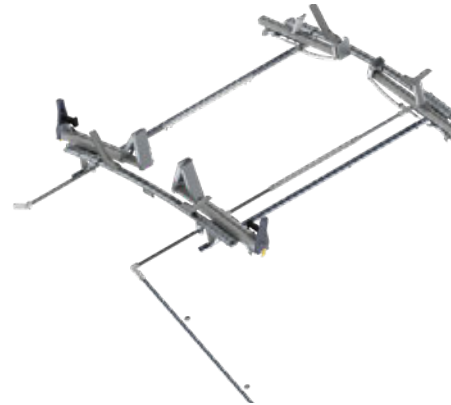

**Aluminum**

			
<b>1820-FTR</b>	130"	Low, Medium	24 ft
<b>1820-FTL</b>	148", 148" Ext	Low, Medium, High	32 ft



Ford Transit  
Max rack, Double side ladder rack

**Aluminum**

			
<b>1830-FTR</b>	130"	Low, Medium	24 ft
<b>1830-FTL</b>	148", 148" Ext	Low, Medium, High	32 ft

## RANGER DESIGN MAX RACK



# Turn-Key Fleet Services



## Ship Through or Local Installation Across North America for all Types of Cargo Vans

We are pleased to offer efficient, personalized service and to answer all questions regarding:

### 1. Analysis

- › Cargo Needs Analysis
- › Custom 3D CAD Layouts
- › Hands-on Equipment Demo

### 2. Testing

- › Test Fitting
- › Pilot Build and Review
- › Optimize Package Based on Technician Feedback

### 3. Delivery

- › Delivery, Production and Installation Planning and Scheduling
- › Vehicle Status Tracking

### 4. Service

- › Dedicated Fleet Account Management Team
- › 350 Ranger Distributor Service Support Network
- › Live Customer Service

**PROUD TO  
BE TOUGH!**

When you want the perfect upfit solution for your work vehicle, turn to Ranger Design. Tested for toughness, Ranger Design's shelving and upfits will take whatever abuse you can dish out. Their unsurpassed craftsmanship, combined with ideal fit and finish, provide a quiet ride with no rattles.



**RANGER**<sup>TM</sup>  
DESIGN

**CUSTOMER SERVICE**

cs@rangerdesign.com  
1-800-565-5321

rangerdesign.com



**THE PERFECT FIT**  
FOR YOUR TOUGHEST JOBS

