

GMC/CHEVROLET

SAVANA/EXPRESS



UPFIT GUIDE





HELPING MOBILE TECHNICIANS WORK MORE EFFECTIVELY BY PROVIDING ORGANIZED STORAGE SOLUTIONS

AT RANGER DESIGN, WE BELIEVE MORE IS POSSIBLE.

We believe work vehicles and the technicians that drive them can become more organized, more efficient, more productive and more profitable. At Ranger Design we're committed to bringing you the products and services that make that possible.

More means helping you choose the right work van for your application, as well as giving you engineering support and expert advice to help design the most efficient work space in your new vehicle.

More also means getting that new van outfitted and on the road faster, so you can start using it for the reason you bought it.

We're committed to bringing you more, because we believe more is possible.



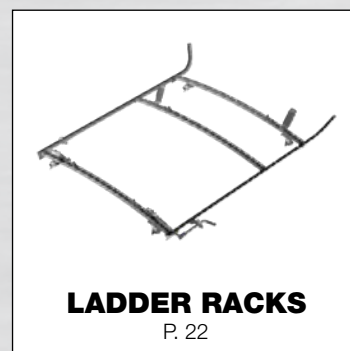
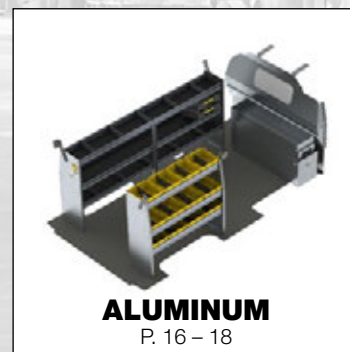

Over 350 Distributors Across the Continent

Buy Ranger Design Quickship service is available through your local distributor. rangerdesign.com/find-dealer

Lead Time Quickship orders placed with Ranger Design before 1PM EST, will ship from our factory in the next business day.



All products shown in this upfit guide are available on Quickship

HOW TO USE THE LAYOUT GUIDE

INSIDE ROOF HEIGHT

To determine the maximum shelf height that can be used in the van.

PARTITION DEPTH

This indicates the space taken up by our partition for this vehicle. Please note that this measurement is determined by the partition that encroaches the most. Some partitions may take up less space. Take note that this measurement may not necessarily be on the floor.

DOOR OPENING

To determine where shelving will land in relation to the door opening. Use this measurement to determine the space available for drawer units.

DIMENSIONS IN RED

These dimensions indicate unique measurements for each wheelbase. Use red dimensions to determine the exact wheelbase of your van.

FLOOR SPACE

This area is usable floor space but due to curvature of the van there may not be the same available area at the roof. Please measure actual van for specific measurement at roof.

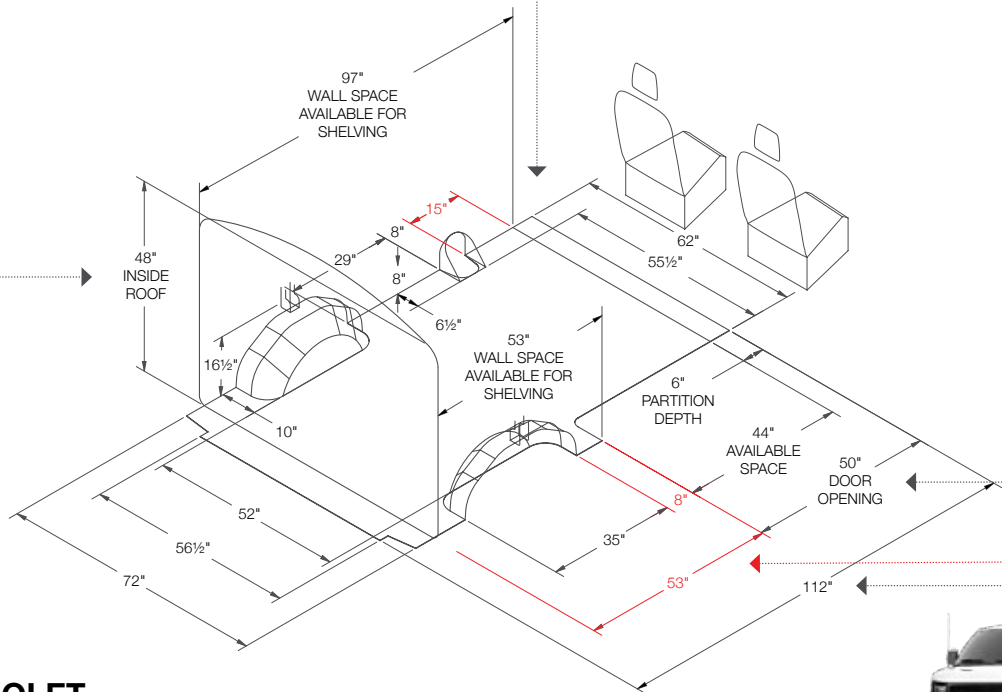

GMC/CHEVROLET SAVANA/EXPRESS

Regular 135" Wheelbase



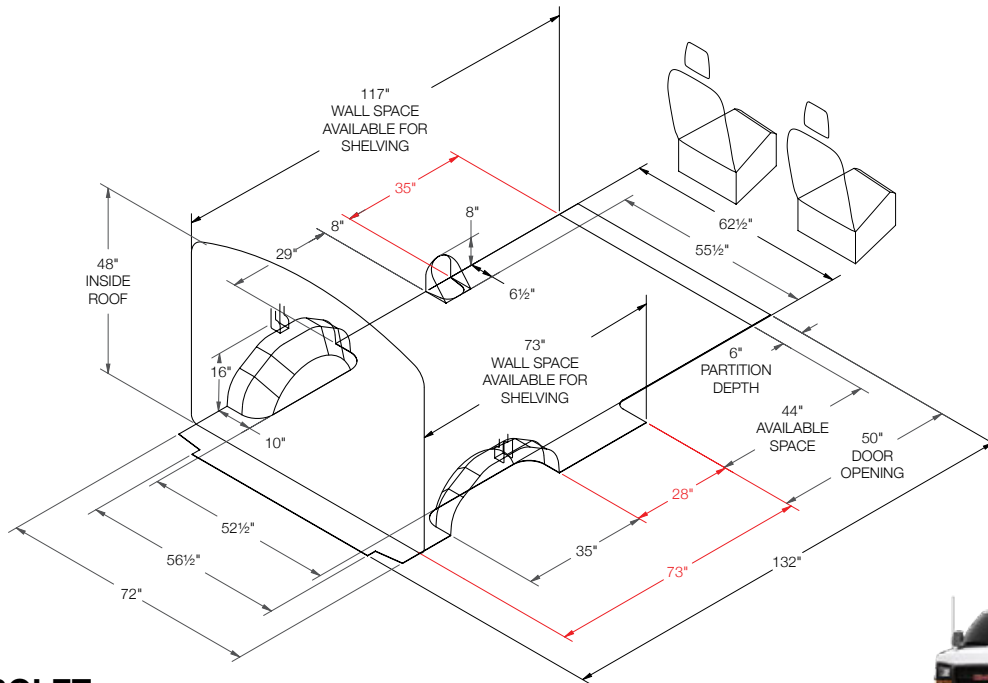

GMC/CHEVROLET
SAVANA/EXPRESS
 Extended 155" Wheelbase

Storage zones

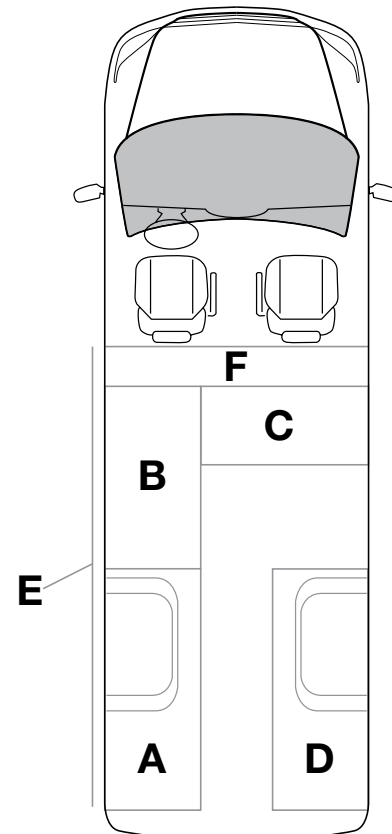

- A** - Driver Side Rear
- B** - Driver Side Front
- C** - Partition and Slide Door
- D** - Passenger Side
- E** - Roof
- F** - Partition

CONTRACTOR

CONTRACTOR

GSR-10

135" WHEELBASE

> Standard Roof



Qty	Part #	Description
1	6070	6" Hook, 3" opening, painted
1	C20-GS	Straight steel partition with perforated window, no access
1	N4-RS48-3	Steel shelving unit for low roof van 14" D x 48" W x 44.5" H
1	N4-RS84-3	Steel shelving unit for low roof van 14" D x 84" W x 44.5" H

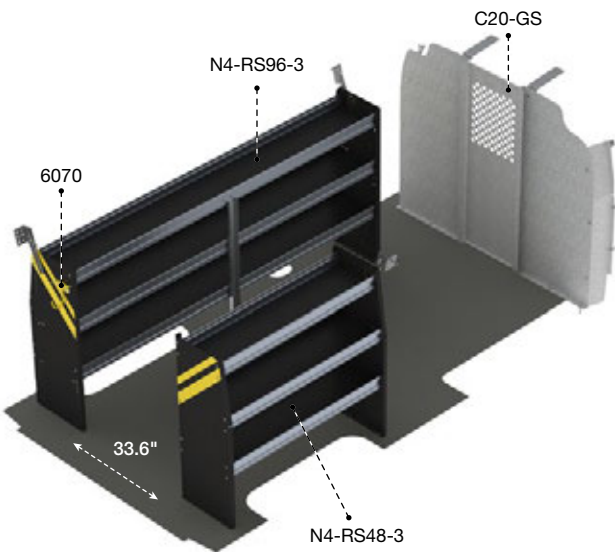
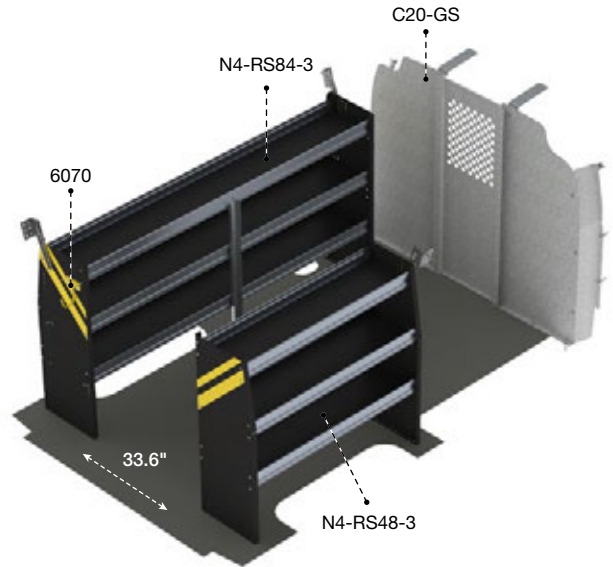

GSL-10

155" WHEELBASE

> Standard Roof



Qty	Part #	Description
1	6070	6" Hook, 3" opening, painted
1	C20-GS	Straight steel partition with perforated window, no access
1	N4-RS48-3	Steel shelving unit for low roof van 14" D x 48" W x 44.5" H
1	N4-RS96-3	Steel shelving unit for low roof van 14" D x 96" W x 44.5" H



GSR-10

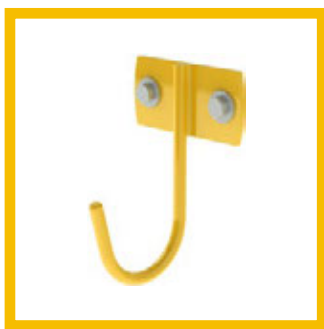

6070

6" Hook,
3" opening,
painted



GSR-16

135" WHEELBASE

> Standard Roof



Qty	Part #	Description
1	6070	6" Hook, 3" opening, painted
1	6072	8" Swivel hook, 4" opening, painted
4	62-U1114	14" deep plastic bin
1	62-UDR12	Set of 5 dividers for a 12" Shelf
1	62-UDR14	Set of 5 dividers for a 14" Shelf
1	C20-GS	Straight steel partition with perforated window, no access
1	N4-RS48-3	Steel shelving unit for low roof van 14" D x 48" W x 44.5" H
1	N4-RS84-3	Steel shelving unit for low roof van 14" D x 84" W x 44.5" H
2	X50-B	Compact 2-drawer unit

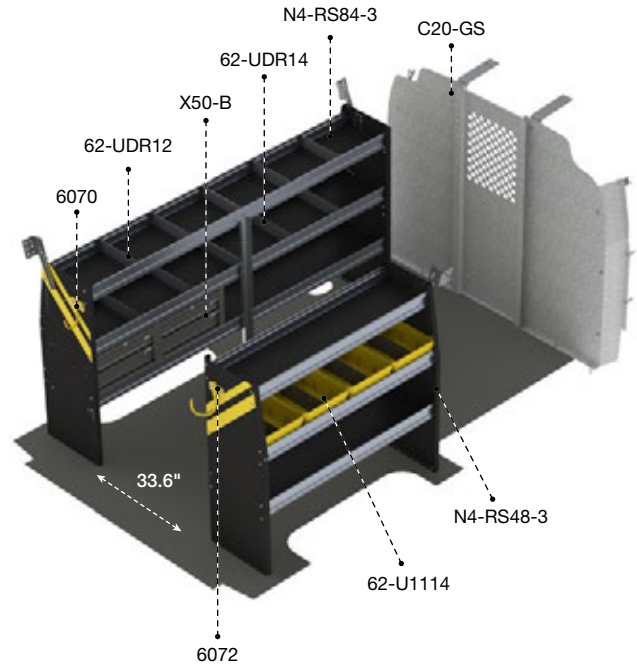

SERVICE

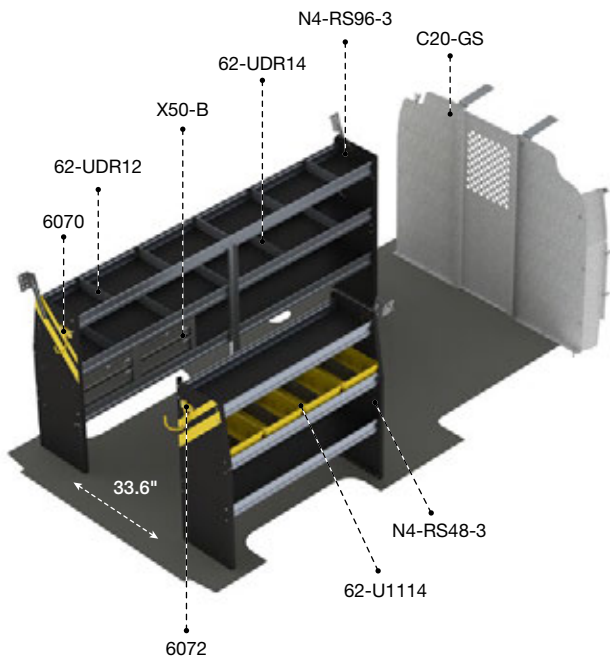

GSL-16

155" WHEELBASE

> Standard Roof



Qty	Part #	Description
1	6070	6" Hook, 3" opening, painted
1	6072	8" Swivel hook, 4" opening, painted
4	62-U1114	14" deep plastic bin
1	62-UDR12	Set of 5 dividers for a 12" Shelf
1	62-UDR14	Set of 5 dividers for a 14" Shelf
1	C20-GS	Straight steel partition with perforated window, no access
1	N4-RS48-3	Steel shelving unit for low roof van 14" D x 48" W x 44.5" H
1	N4-RS96-3	Steel shelving unit for low roof van 14" D x 96" W x 44.5" H
2	X50-B	Compact 2-drawer unit



GSR-16



6072

8" Swivel hook,
4" opening, painted



X50-B

2 Drawer cabinet



62-U1114

14" Deep plastic bin
with a center divider

FOR MORE ACCESSORIES, SEE PAGE 20.

GSR-11

135" WHEELBASE

> Standard Roof



Qty	Part #	Description
1	6063	Paper holder, extra deep, 5 slots
1	6070	6" Hook, 3" opening, painted
1	6072	8" Swivel hook, 4" opening, painted
1	7124	Reel holder with two 5/8" diameter rods
7	62-U1112	12" deep plastic bin
1	62-UDR14	Set of 5 dividers for a 14" Shelf
1	77-U1036	Adjustable shelving door unit - 33" W - for 36" & 72" shelves
1	77-U1048	Adjustable shelving door unit - 45" W - for 48" & 96" shelves
1	C20-GS	Straight steel partition with perforated window, no access
1	N4-RS48-3	Steel shelving unit for low roof van 14" D x 48" W x 44.5" H
1	N4-RS84-3	Steel shelving unit for low roof van 14" D x 84" W x 44.5" H
1	X50-B	Compact 2-drawer unit
1	X50-C	Compact 3-drawer unit

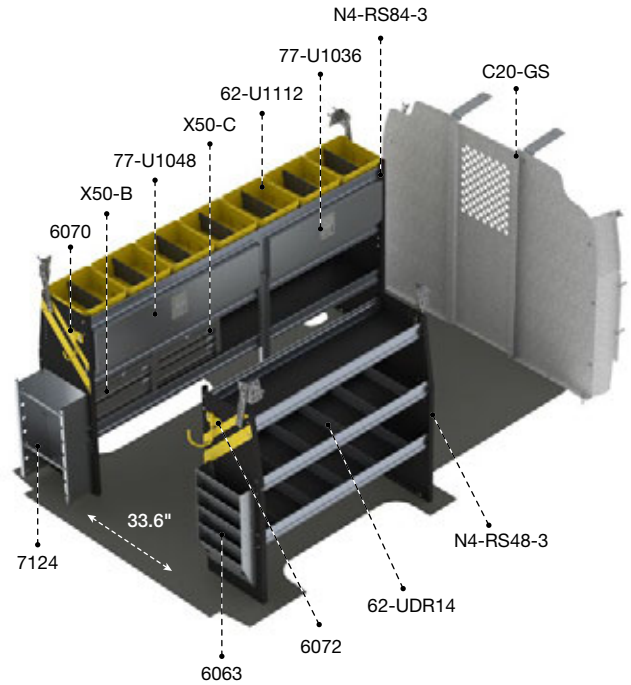

ELECTRICAL

GSL-11

155" WHEELBASE

> Standard Roof

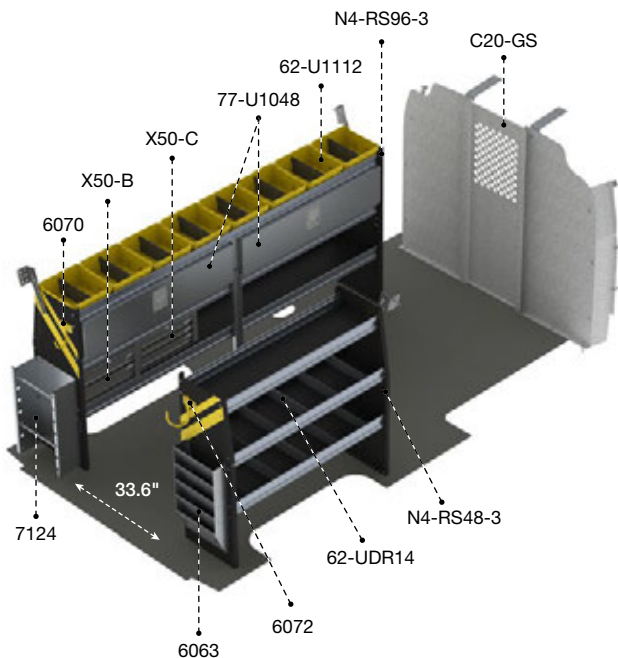

Qty	Part #	Description
1	6063	Paper holder, extra deep, 5 slots
1	6070	6" Hook, 3" opening, painted
1	6072	8" Swivel hook, 4" opening, painted
1	7124	Reel holder with two 5/8" diameter rods
8	62-U1112	12" deep plastic bin
2	62-UDR14	Set of 5 dividers for a 14" Shelf
2	77-U1048	Adjustable shelving door unit - 45" W - for 48" & 96" shelves
1	C20-GS	Straight steel partition with perforated window, no access
1	N4-RS48-3	Steel shelving unit for low roof van 14" D x 48" W x 44.5" H
1	N4-RS96-3	Steel shelving unit for low roof van 14" D x 96" W x 44.5" H
1	X50-B	Compact 2-drawer unit
1	X50-C	Compact 3-drawer unit



GSR-11



**62-U1110, 62-U1112,
62-U1114**

Plastic bins with a center divider
Available in 10", 12" or 14" depths



62-U1212

2 Cross dividers for bin
Fits all size bins



77-U1048

Adjustable shelving door unit
45" wide for a 48" or 96" shelf

FOR MORE ACCESSORIES, SEE PAGE 20.

GSR-12

135" WHEELBASE

> Standard Roof



Qty	Part #	Description
1	6008	3 Tier refrigerant rack for large bottles
1	6063	Paper holder, extra deep, 5 slots
1	6070	6" Hook, 3" opening, painted
1	6072	8" Swivel hook, 4" opening, painted
1	6088	Large aluminum bottle holder, with two black nylon straps
7	62-U1112	12" deep plastic bin
2	62-UDR14	Set of 5 dividers for a 14" Shelf
1	77-U1048	Adjustable shelving door unit - 45" W - for 48" & 96" shelves
1	C20-GS	Straight steel partition with perforated window, no access
1	N4-RS48-3	Steel shelving unit for low roof van 14" D x 48" W x 44.5" H
1	N4-RS84-3	Steel shelving unit for low roof van 14" D x 84" W x 44.5" H
2	X50-B	Compact 2-drawer unit

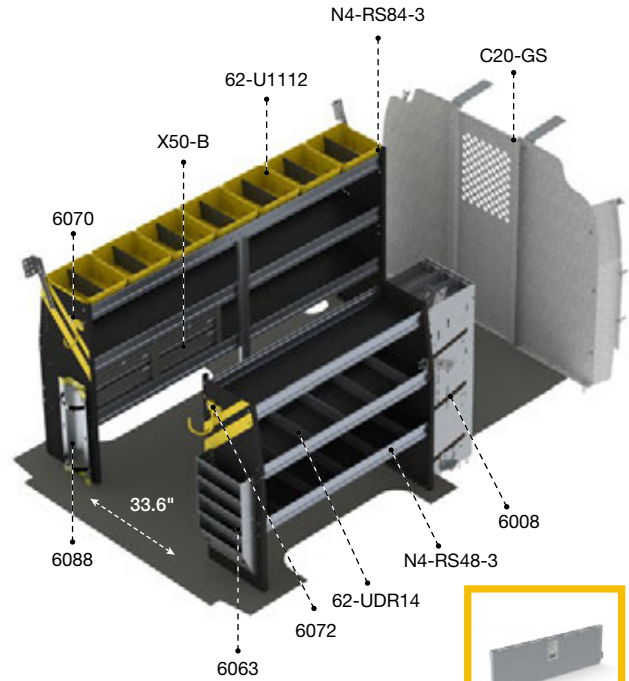

77-U1048

HVAC

GSL-12

155" WHEELBASE

> Standard Roof

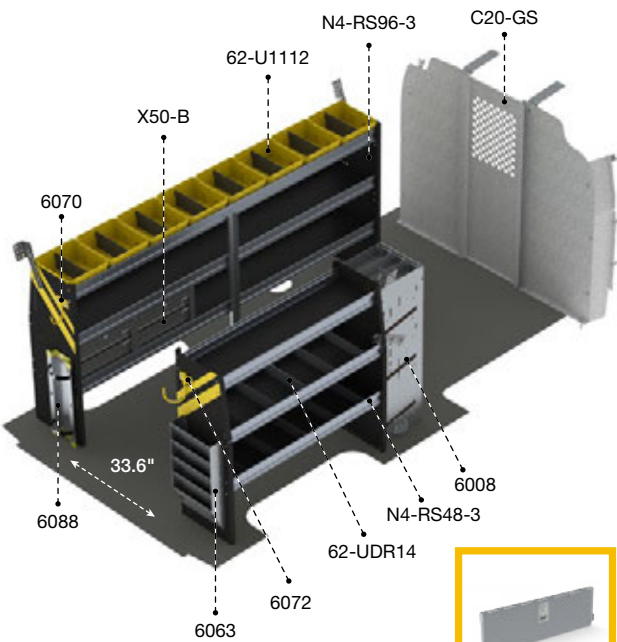

77-U1048

Qty	Part #	Description
1	6008	3 Tier refrigerant rack for large bottles
1	6063	Paper holder, extra deep, 5 slots
1	6070	6" Hook, 3" opening, painted
1	6072	8" Swivel hook, 4" opening, painted
1	6088	Large aluminum bottle holder, with two black nylon straps
8	62-U1112	12" deep plastic bin
2	62-UDR14	Set of 5 dividers for a 14" Shelf
1	77-U1048	Adjustable shelving door unit - 45" W - for 48" & 96" shelves
1	C20-GS	Straight steel partition with perforated window, no access
1	N4-RS48-3	Steel shelving unit for low roof van 14" D x 48" W x 44.5" H
1	N4-RS96-3	Steel shelving unit for low roof van 14" D x 96" W x 44.5" H
2	X50-B	Compact 2-drawer unit



GSR-12



62-UDR14
Set of 5 dividers
for a 14" shelf



6088
Large aluminum bottle holder,
with two black nylon straps



6008
3 Tier refrigerant
rack for large bottles

FOR MORE ACCESSORIES, SEE PAGE 20.

GSR-19

135" WHEELBASE

> Standard Roof



Qty	Part #	Description
1	8548-2	Fold-away shelving unit, 2 levels, 18" D x 55" W x 53.5" H
1	8572-2	Fold-away shelving unit, 2 levels, 18" D x 79" W x 53.5" H
1	C24-GS	Straight walk through steel partition

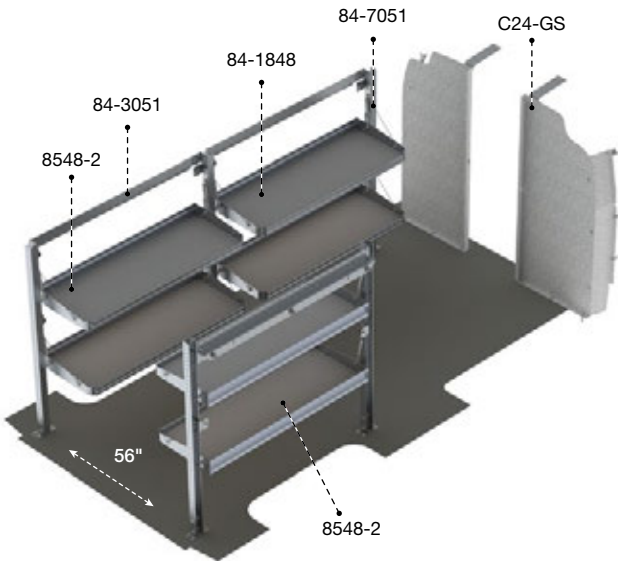
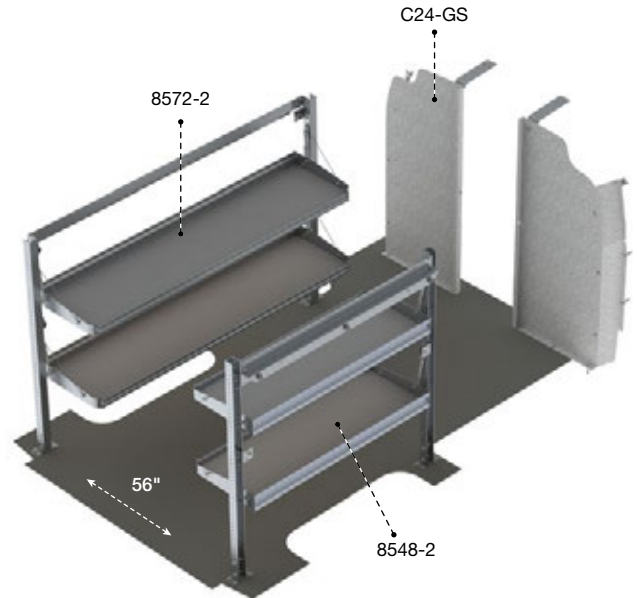

GSL-19

155" WHEELBASE

> Standard Roof



Qty	Part #	Description
2	84-1848	Fold-away shelf tray with gas shocks and hardware, 18" D x 48" W
1	84-3051	Mounting bar assembly, for fold-away shelving, 2"D x 51"W
1	84-7051	Post assembly for fold-away shelving, 2"D x 2" W x 51"H
2	8548-2	Fold-away shelving unit, 2 levels, 18" D x 55" W x 53.5" H
1	C24-GS	Straight walk through steel partition

**GSR-19**

YOUR PERSONAL **FLEX SPACE**

Our fold-away shelves are designed to give you the ultimate in cargo flexibility

- Flexible
- Easy to use
- Tough



THE BENEFITS OF **ALUMINUM**

Weight saving equipment reduces total cost of ownership



Optimize fuel economy by decreasing overall van mass



Reduce vehicle maintenance and repairs caused by weight overload



Increase payload without sacrificing quality – it's a benefit offered only by aluminum

**Did you know that for every 100 lbs reduction,
you increase fuel economy by 1%?**

www.fueleconomy.gov

**Ranger Design is the leader for
aluminum upfits in North America**



GSR-27

135" WHEELBASE

> Standard Roof



Qty	Part #	Description
1	3020-GS	Countoured safety partition with tempered glass window
2	5070	Partskeeper carry case with holder
1	6070	6" Hook, 3" opening, painted
4	62-U1112	12" deep plastic bin
8	62-U1114	14" deep plastic bin
1	62-UDR12	Set of 5 dividers for a 12" Shelf
1	62-UDR14	Set of 5 dividers for a 14" Shelf
1	77-U1048	Adjustable shelving door unit - 45" W - for 48" & 96" shelves
1	N4-RA48-3	Aluminum shelving unit for low roof van 14" D x 48" W x 44.5" H
1	N4-RA84-3	Aluminum shelving unit for low roof van 14" D x 84" W x 44.5" H

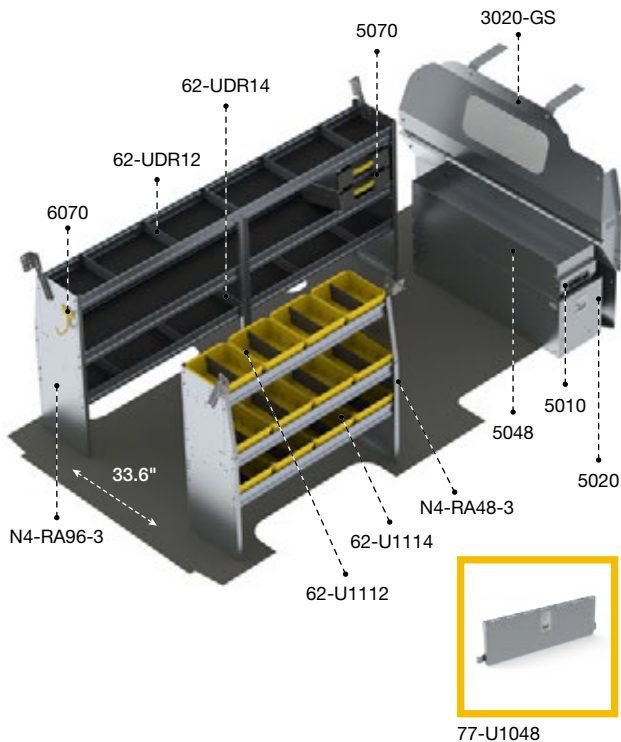
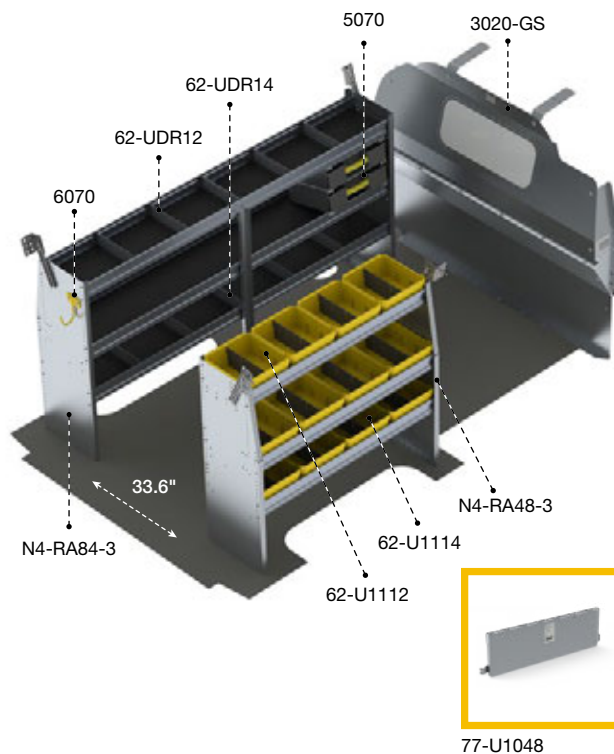

GSL-27

155" WHEELBASE

> Standard Roof



Qty	Part #	Description
1	3020-GS	Countoured safety partition with tempered glass window
1	5010	Partslider drawer 48" D
1	5020	Tool Drawer 48" D x 14" W x 16" H
1	5048	Top edge
2	5070	Partskeeper carry case with holder
1	6070	6" Hook, 3" opening, painted
4	62-U1112	12" deep plastic bin
8	62-U1114	14" deep plastic bin
1	62-UDR12	Set of 5 dividers for a 12" Shelf
1	62-UDR14	Set of 5 dividers for a 14" Shelf
1	77-U1048	Adjustable shelving door unit - 45" W - for 48" & 96" shelves
1	N4-RA48-3	Aluminum shelving unit for low roof van 14" D x 48" W x 44.5" H
1	N4-RA96-3	Aluminum shelving unit for low roof van 14" D x 96" W x 44.5" H



GSR-27

AN ERGONOMIC SOLUTION TO STORAGE

Ranger Design tool drawers offer:

- Accessibility
- Organization
- Security
- Lockable

5020 Tool drawer mounted with a **5010** Partslider drawer and **5048** Top edge.



IT'S MORE THAN A FLOOR!

With incorporated mounting tracks for easy install for most Ranger Design products.

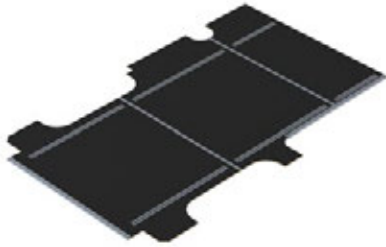

6540-GSR

Savana 135" Floor

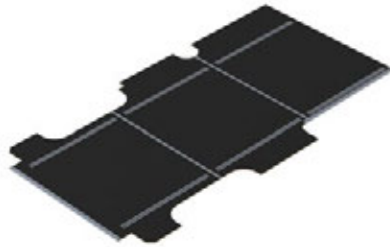

6540-GSX

Savana 155" Floor

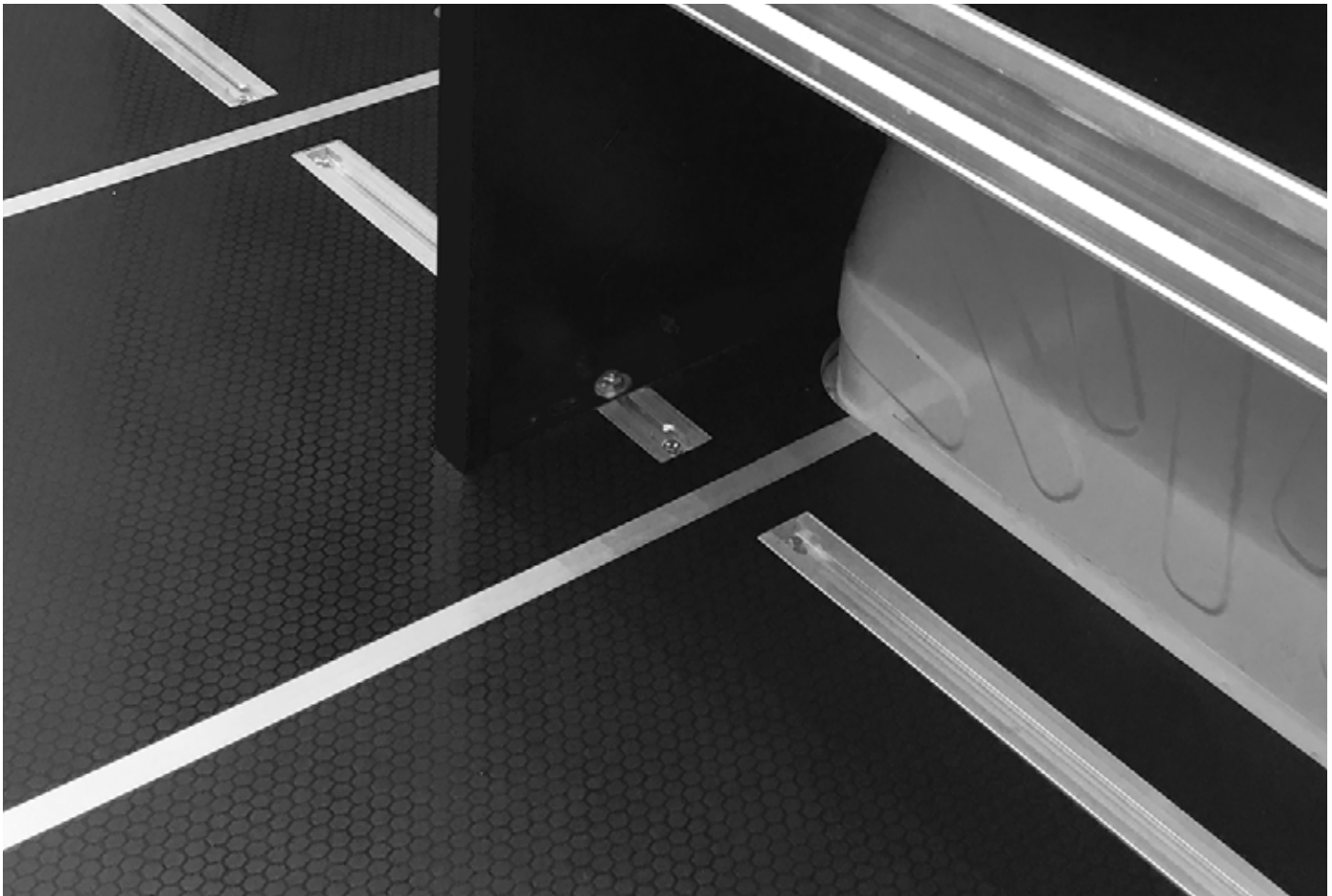
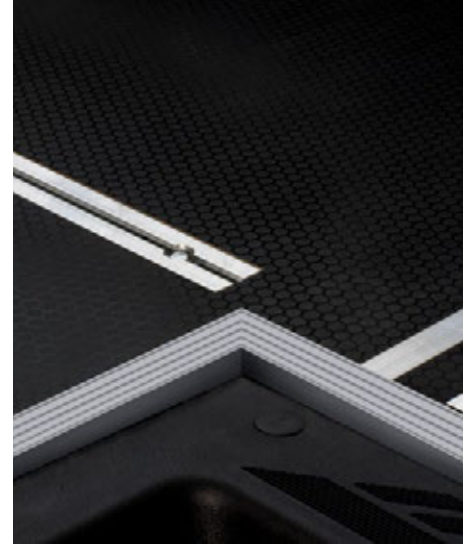

Impact and puncture resistant floors
Preserve the cargo van interior

ACCESSORIES



6010

Two level adjustable bottle holder



6041

Locking cabinet

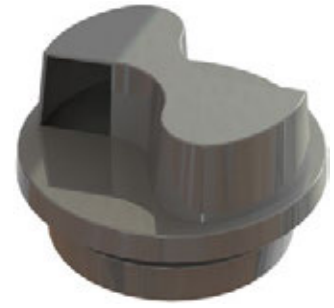

6050

Flettner vent, rotary design



6054

Hitch step, with hitch pin to fit a 2" x 2" hitch



6057

Can holder



6063

Paper holder, extra deep, 5 slots



6068

Hard hat holder, painted wire



6070

6" Hook, 3" opening, painted



6072

8" Swivel hook, 4" opening, painted



6073

Large aluminum movable hook, 6.5" opening



6082

Triangle kit with aluminum holder

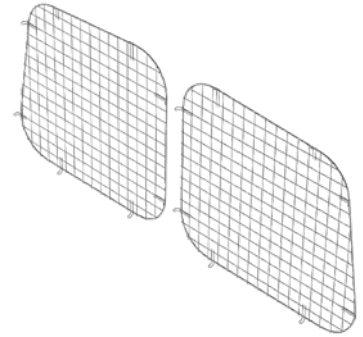

6106

Set of 2 rear window grills

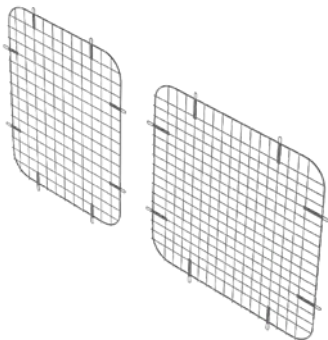

6111

Set of 2 side window grills



62-U1110, 62-U1112, 62-U1114

10", 12" or 14" Deep plastic bin
All bins come with a center divider



62-U1212

2 Cross dividers for bin
Fits all size bins



6252

Seat covers

ENHANCE YOUR VEHICLE WITH CUSTOM SEAT COVERS

- Machine wash and dryer safe
- No interference with factory seat functions (heating, cooling or air bag)
- Tight custom fit for each vehicle, guaranteed to stay in place
- Puncture resistant to prevent seat damage



7124

Reel holder with two 5/8" diameter rods

LADDER RACKS



Access Pro, inside ladder carrier

Aluminum

1050-FS	135", 155"	Standard	



Single clamp ladder rack

Aluminum

1520-FS	135", 155"	Standard	32 ft



Ladder rack accessory

Aluminum

1127	135", 155"	Standard	



Combination ladder rack

Aluminum

1525-FS	135", 155"	Standard	32 ft



Cargo rack

Aluminum

1505-GS	135", 155"	Standard	
1505-GS3	135", 155"	Standard	



Double clamp ladder rack

Aluminum

1530-FS	135", 155"	Standard	32 ft



Standard ladder rack

Aluminum

1510-FS	135", 155"	Standard	

Turn-Key Fleet Services



Ship Through or Local Installation Across North America for all Types of Cargo Vans

We are pleased to offer efficient, personalized service and to answer all questions regarding:

1. Analysis

- › Cargo Needs Analysis
- › Custom 3D CAD Layouts
- › Hands-on Equipment Demo

2. Testing

- › Test Fitting
- › Pilot Build and Review
- › Optimize Package Based on Technician Feedback

3. Delivery

- › Delivery, Production and Installation Planning and Scheduling
- › Vehicle Status Tracking

4. Service

- › Dedicated Fleet Account Management Team
- › 350 Ranger Distributor Service Support Network
- › Live Customer Service

**PROUD TO
BE TOUGH!**

When you want the perfect upfit solution for your work vehicle, turn to Ranger Design. Tested for toughness, Ranger Design's shelving and upfits will take whatever abuse you can dish out. Their unsurpassed craftsmanship, combined with ideal fit and finish, provide a quiet ride with no rattles.



CUSTOMER SERVICE

cs@rangerdesign.com

1-800-565-5321

rangerdesign.com



THE PERFECT FIT
FOR YOUR TOUGHEST JOBS

